

GLA-222-FLP

Gas Leak Alert



AMBETRONICS
AN ISO 9001:2015 CERTIFIED COMPANY

Stay Alert, Make Danger Avert

Commercial Kitchen



Gas Pipeline



Food Court Mall



Gas Bank Area



FRONT VIEW

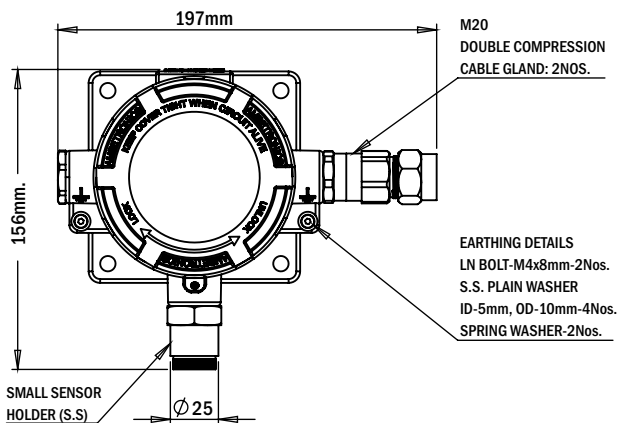

SIDE VIEW

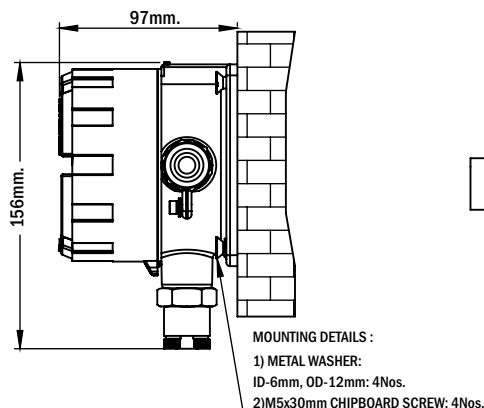

BACK VIEW

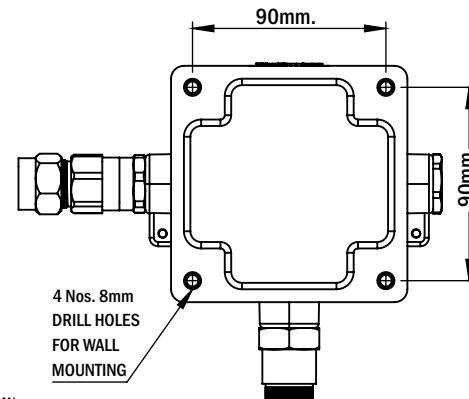

GAS LEAK ALERT is household/Domestic gas alarm wall-mounted & plug-in type designed to detect the concentration of Combustible Gas or vapours using fast response sensors and manufactured with advance featured technology. It provides visual and audible alarms when the gas concentration crosses the pre-set alarm levels and alerts user to take immediate required actions.

FEATURES

- Provides Fast & Reliable Response by using Semiconductor Technology for detecting leak of LPG/CNG/PNG/LNG / Natural Gas / Flammable Gas.
- Optimized for detection of smallest gas leak with integrated Buzzer and L.E.D. indication.
- Provides visual and audible signals when the gas concentration cross the Pre-set Alarm level .
- Helps to detect Gas and Excess Temperature indication.
- Easy installation, simple Plug-in design for home use, 230VAC powered.
- Optional Single Alarm Relay to operate shut off valve.

APPLICATIONS

- Cafeteria
- Gas Bank Ara
- Restaurant Kitchen
- Commercial Kitchen
- Food Court in Mall
- Gas pipeline
- Propane tank stations

TECHNICAL SPECIFICATIONS

GENERAL

Gas Sensor	: Semiconductor
Gas Sampling	: Diffusion
Response time	: Less than 5 sec. at excess leak (Resume Automatically)
Alarm Method	: Visual & Audible
Warm up time	: 1 min

ELECTRICAL

Operating Power	: 18 to 36VDC typically 24VDC
Power Supply	: 3 PIN Adaptor (230VAC)

ENVIRONMENTAL

Operating Temp.	: 0 to +55°C
Storage Temp.	: 0 to +55°C

OUTPUT

Optional	: Single Relay of rating 5A/24VDC, to operate shut off valve
----------	--

ACCESSORIES (Optional)

- Power Supply
- Hooter cum Flasher
- Canopy with mounting stand

TEST FUNCTION

For 'TEST'	: Long press for ACK by using Magnetic Wand
For 'ACK'	: by using Magnetic Wand

DIMENSION

Degree of Protection Class	: IP68
• CIMFR CERTIFICATE NO.	: IN/CIMFR/TR20/3007 Dt : 22/10/2020
• PESO CERTIFICATE NO.	: P492376/2 Dt :13/01/2021
Housing Material	: Cast Aluminium LM6 or Stainless Steel
Cable Entry	: Flameproof, Weatherproof IP66 Double Compression Cable Gland - Model No.: CG/FLP/2C M20 x 1.5 (P)
• CIMFR CERTIFICATE NO.	: CIMFR/TC/P/1313 Dt : 19/09/2018
• PESO CERTIFICATE NO.	: P431645/2 Dt :19/11/2019
Dimension	: 157 mm (H) with sensor holder x 235 mm (W) with Hooter cum Flasher & cable gland x 97 mm (D)
Mounting	: Wall Mounting / Stand Mounting / Pipe Mounting
Weight	: Approx 1.25 Kg

ORDERING INFORMATION

GLA-222-FLP

A

- A) OUTPUT**
1) 4-20mA
2) Relay

B

- B) POWER SUPPLY**
1) 24V DC
2) 230 VAC (with Adaptor)

C

- C) ACCESSORIES**
1) Ambtronics - Hooter Cum Flasher 24VDC operated- ABS Plastic
2) Ambtronics - Hooter Cum Flasher 24VDC operated- SS-316
3) Pipe mounting accessories
4) None

* Before placing the order please refer the above ordering information or Contact below address for assistance.

Manufactured by :



CIMFR



AMBETRONICS ENGINEERS PVT. LTD.

17-B, 16, 14A, Tarun Industrial Estate, New Nagardas Road, Mogra Pada, Andheri (E.) Mumbai - 400 069, India.

+91-22-69623389 +91-93207 37646 sales8@ambtronics.com
+91-22-61673020/21 +91-91674 18106 sales11@ambtronics.com



Follow us on

Version : GLA-222-FLP- R1-01-07-2023

Specifications subject to change without any prior notice