

CRM-212-I

Clean Room Monitor - Integrated Temperature & Humidity Sensor



AMBETRONICS
AN ISO 9001:2015 CERTIFIED COMPANY

Front View
Integrated TRH Sensor



Features

- 7 segments L.E.D. display Indication for Temperature, Humidity at a time
- Independent Programmable Alarm for Temperature, Humidity
- Integrated Buzzer for Alarm limits violation with Acknowledgment facility
- Software calibration facility
- Password protected programming
- Isolated RS-485 communication with MODBUS RTU Protocol

Applications

- Clean room application in Pharmaceutical
- Pharma Environments monitoring applications
- HVAC (Heating, ventilation, Air conditioning, Cooling).
- Animal house clean room
- Cold Storage

TECHNICAL SPECIFICATIONS

Input

Sensor : Integrated Humidity and Temperature Sensor

Range & Resolution

Temperature : -20.0°C to 60°C, 0.1 Resolution
Humidity : 0% to 100% RH, 0.1 Resolution

Accuracy

Temperature : $\pm 1^\circ\text{C}$
Humidity : $\pm 3\% \text{ RH}$

Indication

Display : 2 line 4 digit Seven Segment 0.4" Red L.E.D. display for Temperature & Humidity indication
Status Indication : 2 L.E.D.s for Alarms
Audio Indication : Integrated Buzzer for Alarm violation of any of the 2 parameters, Temperature and Humidity

Communication

RS-485 Slave : Isolated RS-485 communication with MODBUS RTU Protocol
Programmable Settings : Baud rate 9600 bps, Parity (O/E/N), Data bits (8), Stop bits(1/2)
No. of slave ID : 1-250
Minimum Polling interval : 200 milliseconds

Programmable Parameters

Set point : Programmable as per input selection
Programming of parameters : 3 Nos. push button front keys (with password protection)
Alarm logic : High or Low, user programmable

Environmental

Operating Ambient Temp. : 0 to 50°C
Humidity : Below 95% RH, Non condensing.

Electrical

Supply voltage : 24VDC $\pm 10\%$
Power consumption : Less than 1.2 watt at 24VDC

Dimensions

Flush mounting plate : SS-304
Front plate size : 90 mm(H) x 110 mm(W)
Back enclosure : MS with powder coated
Over all Dimension : 90mm(H) x 110 mm (W) x 43mm(D)
Mounting : Modular wall mounting with Stainless Steel Front

DIMENSIONAL DETAILS

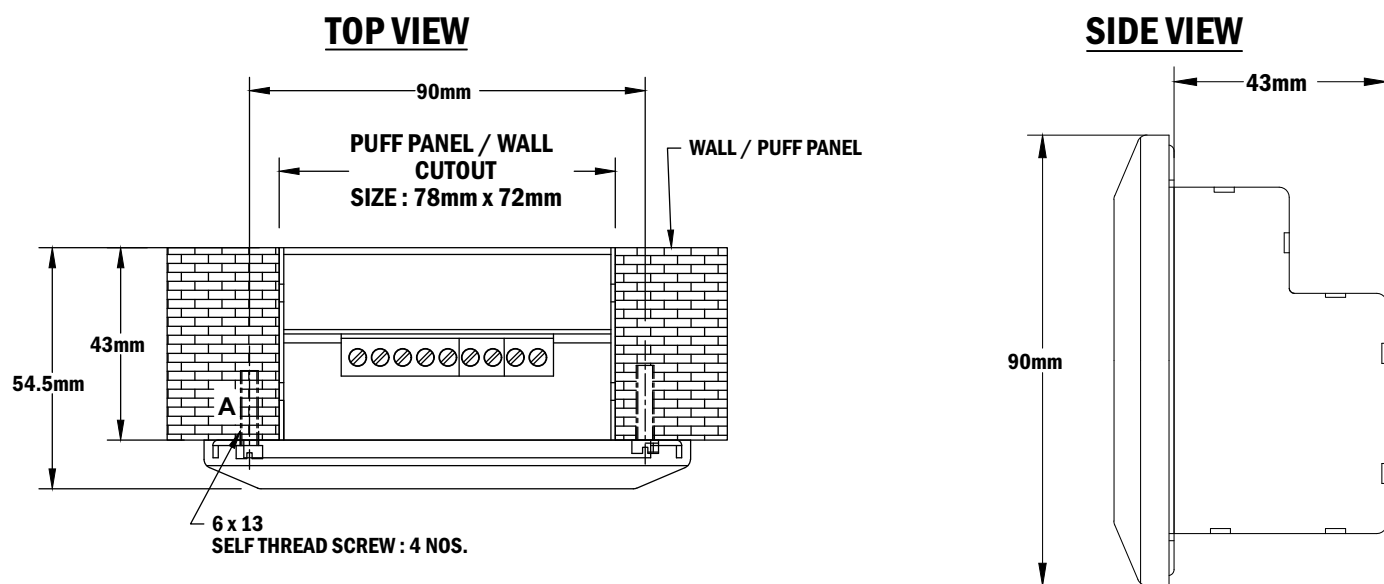
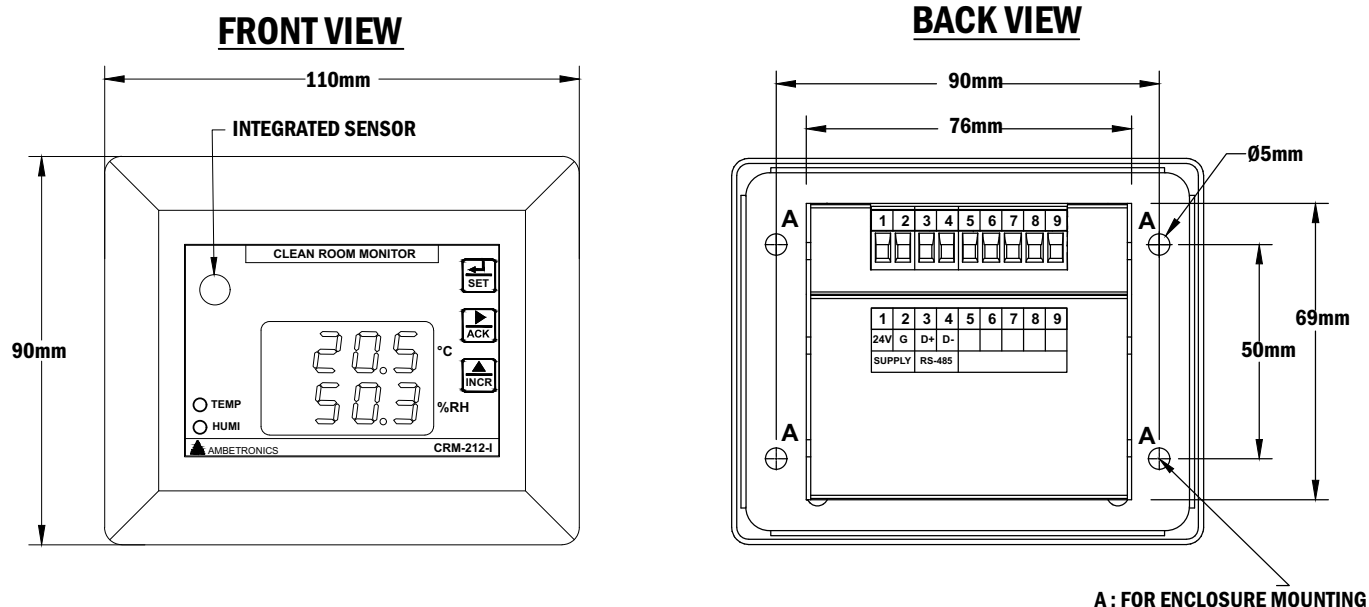

ORDERING INFORMATION

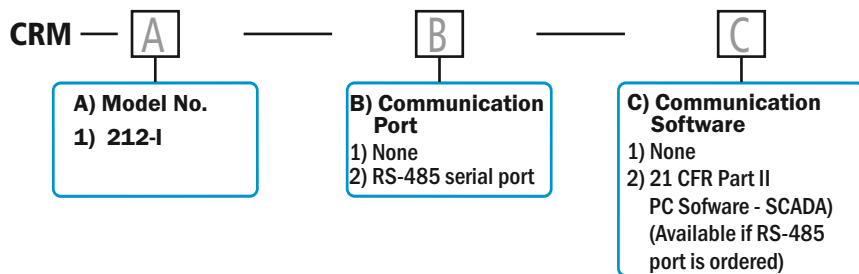

* Before placing order; Refer the above ordering information or Contact below address for assistance.

Manufactured by :



AMBETRONICS ENGINEERS PVT. LTD.
17-B, 16, 14A, Tarun Industrial Estate, New Nagardas Road, Mogra Pada, Andheri (E.) Mumbai - 400 069, India.

+91-22-69623389 +91-93207 37646 sales8@ambetronics.com
+91-22-61673021/22 +91-91674 18106 sales11@ambetronics.com



Follow us on

Version : CRM-212-I-R2-12-01-2024