

Single Channel Portable Gas Detector

PG-100-S



AMBETRONICS
AN ISO 9001:2015 CERTIFIED COMPANY



- Intrinsically Safe
- IS/IEC 60079 Part 11 L-7800047118
- PESO Approved
- EN-50270 EN 61000-6-4 Compliance
- GeM Government e Marketplace
- MAKE IN INDIA

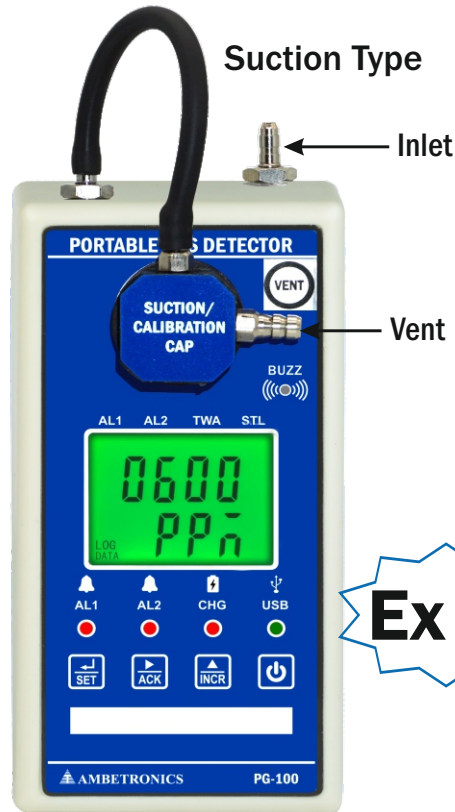

Gas sampling Hose & Probe for Suction Type

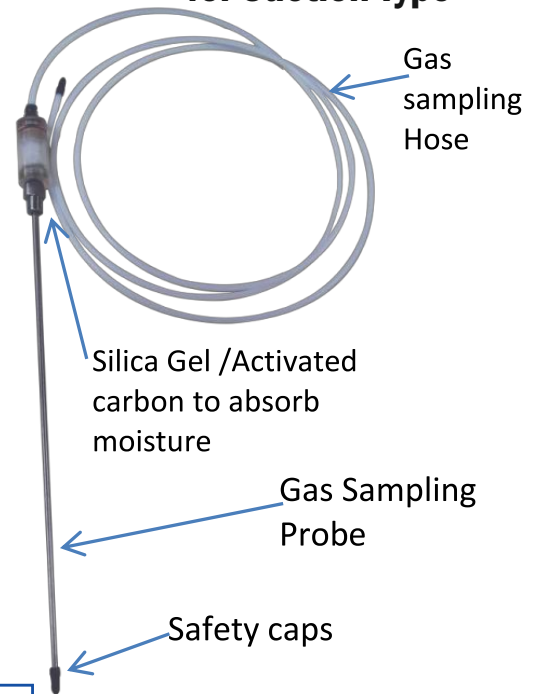

*Actual image and size may slightly differ

Features

- The Plug-in Sensor provides a full year of warranted protection against hazardous gases
- The Portable Detector detects smallest gas leak on service line and joints
- Easy handling and programming with 3 keys and one key for power ON/OFF
- Easy software calibration by using front keys
- Digital display of Gas Concentration in %V/V or %LEL or PPM or PPB or $\mu\text{g}/\text{m}^3$ or mg/m^3 on LCD with backlight unit are adjustable by user setting
- User settable Alarm 1 and Alarm 2 LCD display alert with 5 colors Red / Blue / Yellow/ Cyan / Violet
- Password protected function menu
- LOW, HIGH, TWA & STEL configurable alarms with buzzer, vibrator alerts & LED indications with multi-color display
- "Calibration due" indication and alert
- "Sensor Open/Over" Range Indication In sensor open & over range condition device keep flashing with blue & white colors.
- Optional Data logging & Downloading facility. Downloaded data available in ASCII format (Max: 50,000 records)
- Battery status indication on the LCD with battery charging LED indication & LOW BAT indication with Buzzer Beep sound
- Unit conversion user setting
- Power supply with rechargeable battery
- Small, compact and light-weight
- Pump blockage detection facility in suction type

CERTIFICATE & APPROVALS

INTRINSICALLY SAFE

- CIMFR TR NO. : IN/CIMFR/TR21/R/1341
DATE : 06/08/2021
- BIS MARK LICENCE NO. : 7800047118
- PESO CERT. NO. : P543659/1
DATE : 11/08/2022
- Ex ia IIC T6 Ga : Suitable for Hazardous Gas
- Atmospheres Zone : Zone 1 and Zone 2,
- Including Gas Groups : IIA, IIB & IIC
- IS/IEC 60079-0 : 2011
- IS/IEC 60079-11 : 2006
- IS/IEC 60529 : 2001



Applications

- Emergency response to gas leak
- Incoming Cylinder inspection
- Equipment maintenance
- Pre entry check quality control process
- Waste water treatment plants
- Pulp & Paper Industry
- Steel mills
- Ambient monitoring
- Personal Monitoring
- Refineries & Petrochemical plant including
- Offshore drilling and plant shutdowns

TECHNICAL SPECIFICATIONS

GENERAL

Sensors	: Electrochemical/Catalytic / Pellistor / NDIR / PID
Range/Resolution	: As specified in the table
Detection Method	: Suction
Response Time	: Less than 10 Sec
Parameter Setting	: Setting by 3 keys i.e. (SET, SHIFT, INCR)
Alarm Set Point	: Two independent set points, AL1 & AL2 with LED indication
User settable Alarm 1 and Alarm 2 LCD display	alert with
Settable display	5 colors Red / Blue / Yellow / Cyan / Violet Indicated by Integrated Vibrator & Buzzer (85dB Audible from 1 feet)
Display	:2-line LCD with backlit. Normal mode White/ Green in colour

ACCURACY

Sr. No.	SENSOR TECHNOLOGY	CAL ACCURACY
1	Electrochemical	± 2 % FS
2	Catalytic / Pellister	± 2 % FS
3	NDIR - CH ₄	± 0.2 % V/V OR ± 5% of applied gas whichever is max
4	NDIR - CO ₂	± 10 % of applied gas
5	PID Range	0 to 5000 PPM ± 10% of applied gas
		0 to 1000 PPM ± 5% of applied gas
		0 to 50 PPM ± 3% of applied gas

ENVIRONMENTAL

Operating Temp.	: -10°C to +55°C
Storage Temp.	: -10°C to +60°C
Humidity	: Below 95% RH, Non condensing

ELECTRICAL : 3.7V LI-PO RECHARGEABLE BATTERY

BACK UP DETAILS			
Sr. No	DETECTOR TYPE	W/O VIOLATION	WITH VIOLATION
1	Toxic/ O ₂ / N ₂	10 DAYS	24 HOURS
2	PID/NDIR (CO ₂ / CH ₄)	2 DAYS	18 HOURS
3	Catalytic / Pellistor	4 HOURS	2 HOURS

COMMON DELIVARABLES

- Test calibration certificate
- Reference calibration gas certificate
- User Manual
- AC Charger Adaptor
- Protection rubber cover
- USB cable (only for data logging option)
- Calibration Cap for Diffusion type

SUCTION ACCESSORIES

- Calibration & Suction cap
- Gas Sensing Probe : Std. size 13", Above 13" available on request
- Gas Sampling Hose : PVC

OPTIONAL DATA LOGGING

Logging Capacity	: 50,000 records with data available in ASCII format
Data Download	: To the PC Through USB interface using Terminal software

DIMENSIONS & WEIGHT

Material	: ABS Plastic
Size	
Suction Type	: 150 mm(H) x 70 mm(W) x 50 mm(D)
Weight	
Suction Type	: 260 Grams

LIST OF AVAILABLE GASES WITH RANGE & RESOLUTION

ELECTROCHEMICAL SENSOR TECHNOLOGY

SR. NO.	GASES		RANGE	UNIT	RES.
01	Oxygen	(O ₂)	25	% V/V	0.01
02	Oxygen	(O ₂)	100	% V/V	0.1
NT1	Nitrogen	(N ₂)	100	% V/V	0.1
TOXIC GASES					
T1	Ammonia	(NH ₃)	100	PPM	1
T2	Ammonia	(NH ₃)	1000	PPM	1
T3	Bromine	(Br ₂)	10	PPM	0.1
T4	Carbon Monoxide	(CO)	1000	PPM	1
T5	Carbon Monoxide	(CO)	99.99	mg/m ³	1
T6	Chlorine	(Cl ₂)	20	PPM	0.1
T7	Hydrogen	(H ₂)	2000	PPM	1
T8	Hydrogen Bromide	(HBr)	100	PPM	1
T9	Hydrogen Chloride	(HCL)	100	PPM	1
T10	Hydrogen Cyanide	(HCN)	100	PPM	1

SR. NO.	GASES		RANGE	UNIT	RES.
T11	Ethylene Oxide	(C ₂ H ₄ O)	250	PPM	1
T12	Hydrogen Fluoride	(HF)	10	PPM	0.1
T13	Hydrogen Fluoride	(HF)	100	PPM	1
T14	Hydrogen Sulfide	(H ₂ S)	100	PPM	1
T15	Ozone	(O ₃)	20	PPM	0.1
T16	Ozone	(O ₃)	9999	µg/m ³	1
T17	Phosphine	(PH ₃)	10	PPM	0.1
T18	Nitrogen Dioxide	(NO ₂)	20	PPM	0.1
T19	Nitrogen Dioxide	(NO ₂)	9999	µg/m ³	1
T20	Nitric Oxide	(NO)	250	PPM	0.1
T21	Sulphur Dioxide	(SO ₂)	50	PPM	0.1
T22	Sulphur Dioxide	(SO ₂)	2000	PPM	1
T23	Sulphur Dioxide	(SO ₂)	9999	µg/m ³	1

NDIR SENSOR TECHNOLOGY

SR. NO.	GASES		RANGE	UNIT	RES.
N1	Carbon Dioxide	(CO ₂)	5000	PPM	1
N2	Carbon Dioxide	(CO ₂)	2000	PPM	1
N2	Carbon Dioxide	(CO ₂)	5	% V/V	0.1
N3	Carbon Dioxide	(CO ₂)	100	% V/V	1
N4	Methane	(CH ₄)	100	% LEL	1
N5	Methane	(CH ₄)	5	% V/V	0.1
N6	Methane	(CH ₄)	100	% V/V	1

SR. NO.	GASES		RANGE	UNIT	RES.
N7	Propane / LPG	(C ₃ H ₈)	100	% LEL	1
N8	Propane / LPG	(C ₃ H ₈)	5	% V/V	0.1
N9	Propane / LPG	(C ₃ H ₈)	100	% V/V	1
N10	NITRUS OXIDE	(N ₂ O)	1000	PPM	1
N11	Sulphur Hexa Fluoride	(SF ₆)	1000	PPM	1
N12	Refrigerant	(R-134a)	1000	PPM	1

LIST OF AVAILABLE GASES WITH RANGE & RESOLUTION

CATALYTIC/PELLISTOR SENSOR TECHNOLOGY

COMBUSTIBLE GASES

SR. NO.	GASES		RANGE	UNIT	RES.
C1	Acetone	(CH ₃) ₂ CO	100	% LEL	1
C2	Acetylene	(C ₂ H ₂)	100	% LEL	1
C3	Ammonia	(NH ₃)	100	% LEL	1
C4	Butane / n-Butane	(C ₄ H ₁₀)	100	% LEL	1
C5	Carbon Monoxide	(CO)	100	% LEL	1
C6	Ethanol	(C ₂ H ₅ OH)	100	% LEL	1
C7	Ethyl Acetate	(C ₄ H ₈ O ₂)	100	% LEL	1
C8	Ethylene	(C ₂ H ₄)	100	% LEL	1
C9	Ethylene Oxide	(C ₂ H ₄ O)	100	% LEL	1
C9	Hexane/n-Hexane	(C ₆ H ₁₄)	100	% LEL	1
C10	Hydrogen	(H ₂)	100	% LEL	1
C11	Isopropanol	(CH ₃ C ₂ H ₄ OH)	100	% LEL	1
C12	Methane	(CH ₄)/(HC)	100	% LEL	1
C13	Methyl Ethyl Ketone	(C ₄ H ₈ O)	100	% LEL	1
C14	Methanol	(CH ₃ OH)	100	% LEL	1
C15	N-Heptane	(C ₇ H ₁₆)	100	% LEL	1
C16	N-Pentane	(C ₅ H ₁₂)	100	% LEL	1
C17	Pentane/n-Pentane	(C ₅ H ₁₂)	100	% LEL	1
C18	Propane/n-Propane/LPG	(C ₃ H ₈)	100	% LEL	1
C19	Toluene	(C ₇ H ₈)	100	% LEL	1
C20	Unleaded Petrol		100	% LEL	1
C21	CNG/LNG/LPG/Natural Gas/Flammable Gas		100	% LEL	1

PID SENSOR TECHNOLOGY

SR. NO.	GASES	RANGE	UNIT	RES.
P1	Isobutylene (C ₄ H ₈)/ Other VOC	50	PPM	0.1
P2	Isobutylene (C ₄ H ₈)/ Other VOC	1000	PPM	1
P3	Isobutylene (SPAN C ₄ H ₈)/Other VOC	5000	PPM	1

NOTE:

- In above table , range of gases start from zero.
- Confirm Gas sampling Hose length by enquiry & it is available only for Suction type detector.
- Gases which are not listed, are available on request & for other details contact factory.
- All VOC's are available in PID detection principle in PPM ranges.
- PID detector will be provided by calibration with Isobutylene gas.
- In PID detector, VOC other than Isobutylene is calibrated with Isobutylene gas by setting VOC correction factor,
- In Calibration Report, VOC factor with respect to Isobutylene gas will be mentioned.
- Detection value of VOC = Isobutylene gas concentration value x factor.

DIMENSIONAL DETAILS OF GAS DETECTOR

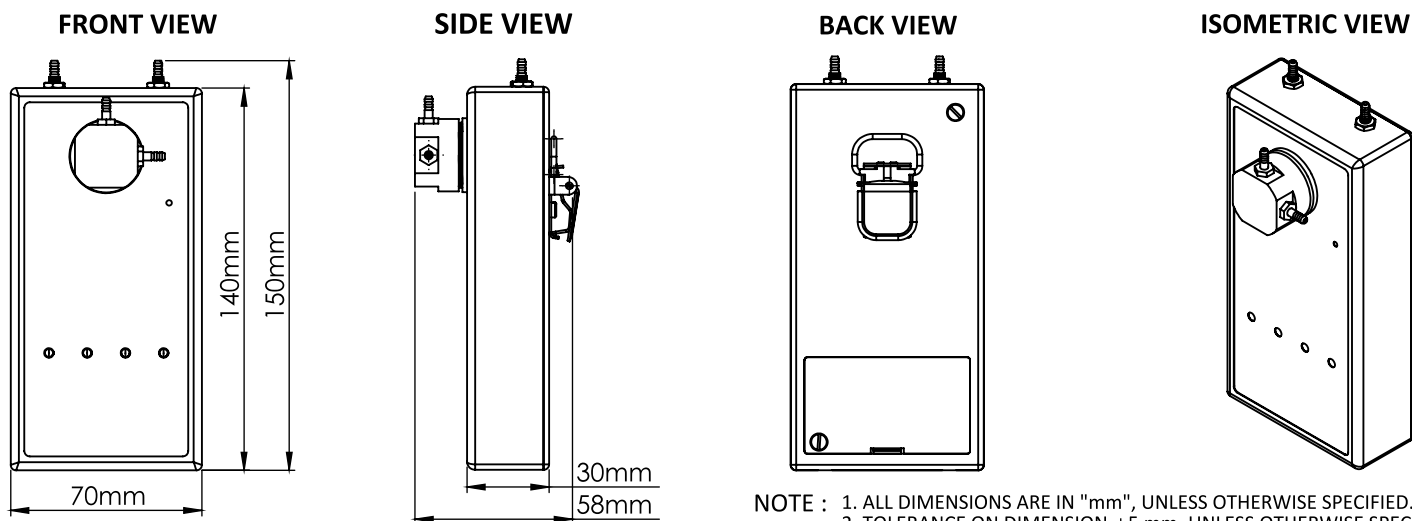

NOTE : 1. ALL DIMENSIONS ARE IN "mm", UNLESS OTHERWISE SPECIFIED.
 2. TOLERANCE ON DIMENSION ±5 mm, UNLESS OTHERWISE SPECIFIED.

ORDERING INFORMATION

MODEL NO PG - 100	DETECTION METHOD 1) S = Suction	DATA LOGGING OPTION 1) No Suffix = No Data Logging	GAS NUMBER, RANGE, RESOLUTION Refer Gas List
-----------------------------	---	--	--

Manufactured by :



AMBETRONICS ENGINEERS PVT. LTD.

17-B, 16, 14A, Tarun Industrial Estate, New Nagardas Road, Mogra Pada, Andheri (E.) Mumbai - 400 069, India.

+91-22-69623389 +91-93207 37646 sales8@ambetronics.com
 +91-22-61673021/22 +91-91674 18106 sales11@ambetronics.com



Follow us on